

PP PROPYLUX[®] HS

The Clear Solution for Orthopedic Devices

PROPYLUX[®] HS rods are exclusively produced by Westlake Plastics.

Launched in 2004 by Westlake Plastics Europe, PROPYLUX[®] HS has gained wide acceptance by orthopedic device manufacturers in Europe.

PROPYLUX[®] HS products deliver the required attributes for orthopedic applications including biocompatibility, chemical resistance and dimensional stability.

At a similar price point as POMALUX, PROPYLUX[®] HS offers superior dimensional stability performance when processed through repeated 134°C Prion autoclaving cycles. The material also provides excellent chemical resistance to disinfecting and cleaning solutions and exhibits a very good balance of strength, toughness and ductility.

As such, PROPYLUX[®] HS is well suited for use in applications including trial heads and cups for hip implants, knee provisional trials and impactor applications.

The PROPYLUX[®] HS product line consists of 15 colors and 13 diameters. All colored materials are made with FDA compliant ingredients and the shaped rods have been tested and comply with key parts of ISO 10993.

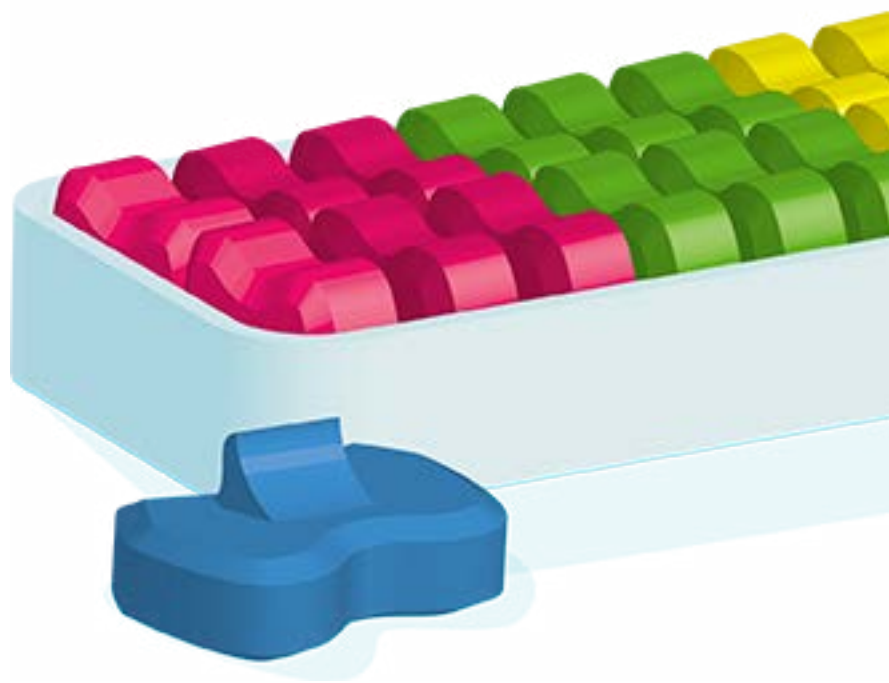
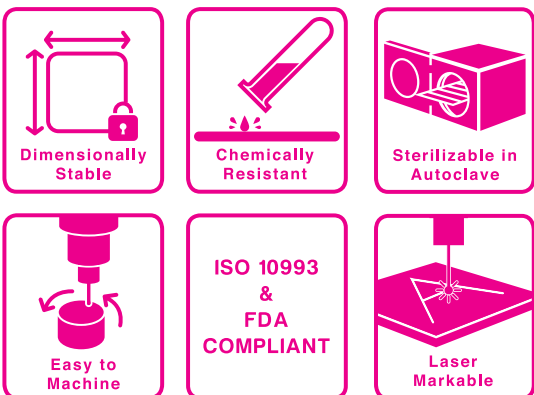
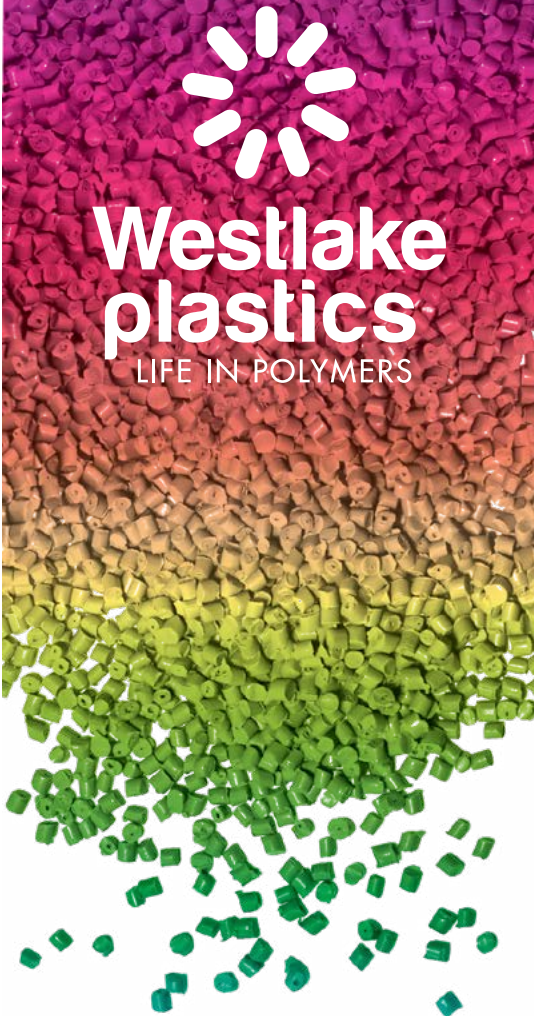

**ISO 10993
&
FDA
COMPLIANT**

Regulatory Compliance

Colored **PROPYLUX® HS** rods feature a unique biocompatibility profile that combines testing per color on fabricated parts using GLP protocol.

The fabricated parts were soaked in machining lubricant for 72 hours to simulate “worst-case” conditions and then cleaned.

The performance of the cleaning process was assessed by a chemical characterization test (ISO 10993-18). Claiming equivalence to our biocompatibility tests is made easy by accessing our US FDA Master Access File (for the US market only).

- The polypropylene resin conforms to FDA. 21 CFR 177.1520(c)3.2a as well as USP Class VI
- Pigments conform to FDA 21 CFR 178.3297
- Additives conform to FDA 21 CFR 182.8994, 21 CFR 178.2010 and 21 CFR 178.3400
- **PROPYLUX® HS** is FDA Master File listed. Contact Westlake Plastics for access authorization and further information.
- **PROPYLUX® HS** shaped colored materials have been tested and are compliant with key parts of ISO 10993 as outlined in the tables below.

Use of International Standard ISO 10993-1,
"Biological evaluation of medical devices
Part 1: Evaluation and testing within a risk management process"
US FDA Guidance Published in June 16th, 2016

	Limited Contact Duration (≤ 24 hours)	Prolonged Contact Duration (> 24 hours to 30 days)	Permanent Contact Duration (≥ 30 days)
Surface device in contact with intact skin	Approved	Approved	Approved
Surface device in contact with mucosal membrane	Approved	Approved	N/A
Surface device in contact with breached or compromised surface	Approved	Approved	N/A
External communicating device in contact with blood path, indirect	Approved	Approved	N/A
External communicating device in contact with tissue/bone/dentin	Approved	N/A	N/A
External communicating device in contact with circulating blood	Approved	N/A	N/A
Implant device in contact with tissue/bone	Approved	N/A	N/A

ISO 10993 Testing	Black	Dark Blue	Light Blue	Brown	Neon Green	Dark Green	Grey	Orange	Red	Yellow	White	Magenta	Aqua	Violet	Rust
Chapter 5 Cytotoxicity	✓	✓	✓	✓	✓	✓	✓	✓	✓	✓	✓	✓	✓	✓	✓
Chapter 10 Intracutaneous Irritation	✓	✓	✓	✓	✓	✓	✓	✓	✓	✓	✓	✓	N/A	N/A	N/A
Chapter 10 Maximization/Sensitization	✓	✓	✓	✓	✓	✓	✓	✓	✓	✓	✓	✓	N/A	N/A	N/A
Chapter 11 Acute Systemic Toxicity	✓	✓	✓	✓	✓	✓	✓	✓	✓	✓	✓	✓	N/A	N/A	N/A
Chapter 11 Material-Mediated Pyrogenicity	✓	✓	✓	✓	✓	✓	✓	✓	✓	✓	✓	✓	N/A	N/A	N/A



Steam Sterilization

PROPYLUX® HS can be repeatedly steam sterilized at either 134°C/18 min or 121°C/30 min.

Westlake Plastics has successfully tested **PROPYLUX® HS** up to 500 cycles (134°C/18") with no major shift in dimensional stability or color fading. Polypropylene shows very low moisture absorption (10 times lower than Acetal POM C per ASTM D570). It is to be noted that **PROPYLUX® HS** will expand during autoclaving cycle and shrink to its original shape as it cools down.

Consequently, we advise to perform development testing for instrument handles in which **PROPYLUX® HS** would be constrained on both sides (ie: impactor handle).

PROPYLUX® HS is very well suited for other devices like trial heads and cups, trial knees and patellas, trial humeral cups or impactor bumpers.

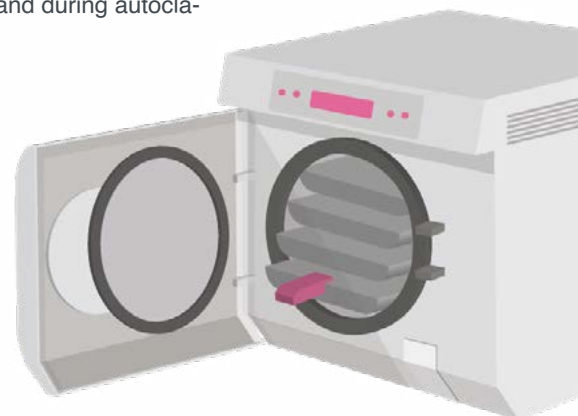



Chemical Resistance Study : simulated worst-case neutralizing process

Chemical resistance is a critical characteristic for orthopedic devices which undergo repeated cleaning and disinfection cycles over their lifespan. **PROPYLUX® HS** offers excellent resistance to a wide range of chemicals including acidic and alkaline solutions. To highlight this comparative basis, **PROPYLUX® HS** along with POM C and PPSU were exposed to a worst-case acidic neutralizing process and evaluated for a visible sign of attack.

- Machined trial heads soaked in phosphoric acid (PH 2.5) for 10 minutes. (Phosphoric acid is commonly used as neutralizing agent)
- No rinsing
- Components were dried with hot air for 15 minutes

As shown in the photos and summarized in the table below, **PROPYLUX® HS** exhibited excellent chemical resistance and superior performance compared to POM C. This test highlights that Propylux offers an additional factor of safety against strong acids.



Effects of Passivation Process	POM C	PPSU	PROPYLUX HS
Discoloration / Mottling	Moderate	None	None
Stress Cracking	Slight	None	None
Etching	Severe	None	None
Outgassing	Severe	None	None

None : no visible change to exposed surfaces
Slight : changes noticeable with the naked eye affecting less than 25% of exposed surface
Moderate : changes noticeable with the naked eye affecting more than 25% of exposed surface
Severe : changes noticeable with the naked eye affecting more than 50% of exposed surface

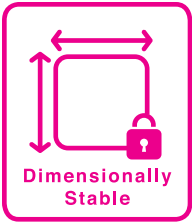

Dimensional Stability

An internal study confirmed the ability of **PROPYLUX® HS** to maintain its excellent dimensional stability at 50 autoclave cycles (tests not run to failure). Trial hip parts (head & cup) were chosen to perform this test with the most critical parameters being evaluated with 3D CMM equipment.

In each case **PROPYLUX® HS** shows a far better dimensional stability than POM C and equivalence to PPSU. According to many orthopedic device manufacturers, **PROPYLUX® HS** can withstand over 500 autoclaving cycles.



Diameter (mm) **Trial Head - External Sphere**

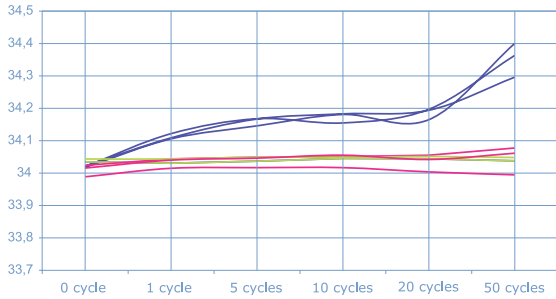

Angle (°) **Trial Head - Cone**

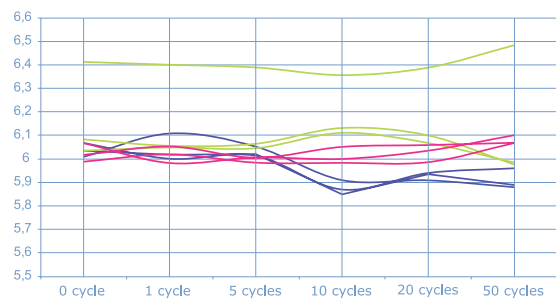

Diameter (mm) **Trial Cup - Internal Sphere**

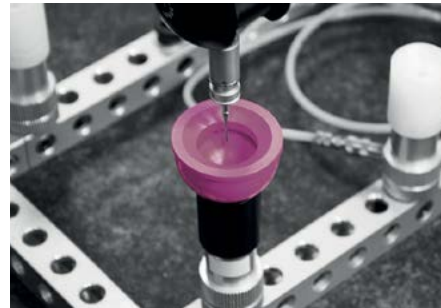
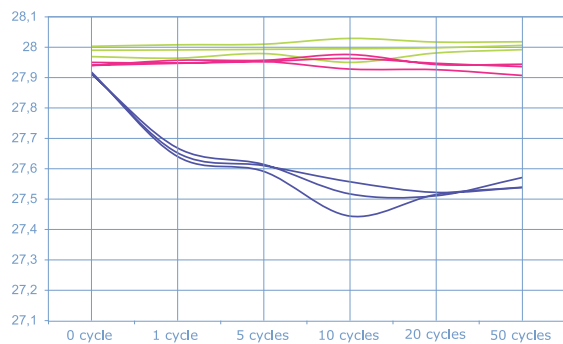

Diameter (mm) **Trial Cup - External Sphere**

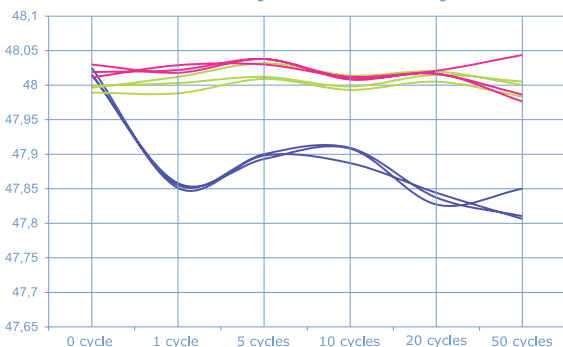



Laser Engraving

All **PROPYLUX® HS** colors are suitable for laser engraving. Machine settings and results will vary depending on the type of laser marking system used. The sample pieces in the picture on the right were marked using a fiber YAG laser system. Best results are obtained using a UV laser.

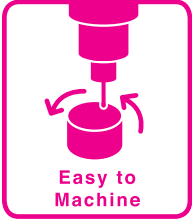
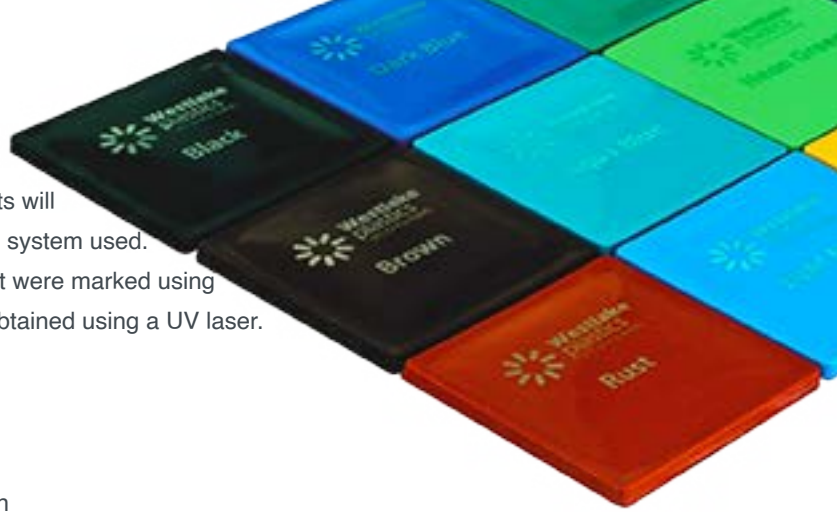

Machining

PROPYLUX® HS is easily machined into intricate parts with complex designs. We can provide technical advice on the machining of **PROPYLUX HS** products.

	APPLICATIONS					STERILIZATION METHOD				SHAPES	
	Container and Brackets	Surgical instruments handles	Impactor devices	Large and Small joint trial devices	Large and Small joint implant devices	Gamma	Low TA ^o Sterilization	etO	Autoclaving 134°C or 121°C	Sheets/Slabs	Rods
PROPYLUX® HS WM <small>The Clear Solution for Orthopedic Devices</small>	NB		****	****	N/A		****	****	****	N/A	Diame-0.5" to
PROPYLUX® HS² WM <small>The Clear Solution for Orthopedic Devices</small>	****	NB	NB	NB	N/A		****	****	****	0.5" to	N/A
RADEL® WM <small>Medical Grade</small>	***	****	***	****	N/A	**	****	****	****	0.5" to	Diame-0.5" to
LENNITE® WM <small>Implantable Grade</small>	N/A	N/A	N/A	N/A	****	****	N/A	****	N/A	N/A	Diame-0.5" to
ZELUX® WM <small>General Purpose</small>	N/A	Single Use	Single Use	Single Use	N/A	****	No data	***		0.5" to 2.5"	Diame-0.5" to

- Repealable-Use Polymers
- Implantable Polymer
- Single Use Polymer

N/A: Non applicable.

NB: Can be used but stock shape format and/or biocompatibility are not best suited.

- Poor
- Medium
- Good
- Optimal

Properties based on typical values of extruded rod

Properties of the resin	ASTM Method	SI Units	Imperial Units
Physical Characteristics			
Density	D1505	0.90 g/cm ³	0.90 g/cm ³
Water absorption	D570	0.025 %	0.025 %
Mechanical Characteristics			
Tensile Strength @ Yield	D638	34.7 MPa	5.04 kpsi
Tensile Strength @ Break	D638	27.3 MPa	3.96 kpsi
Tensile Elongation @ Yield	D638	4.6 %	4.6 %
Tensile Elongation @ Break	D638	20 % - 60 %	20 % - 60 %
Tensile Modulus	D638	20.1 MPa	292 kpsi
Izod impact (0.50") @ Notched	D256	0.48 J/cm	0.90 ft-lbs/in
Izod impact (0.50") @ Un-Notched	D256	No Break	No Break
Hardness (R scale)	D785	92	92
Thermal Characteristics			
Heat Deflection Temp at 66 psi	D648	150°C	302°F
Heat Deflection Temp at 264 psi	D648	71°C	160°F

15 Standard Colors

We have developed a range of 15 standard colors to code your instrumentations. If additional colors are needed, let us work with you to develop new colors. We can make it standard or keep it exclusive to you.

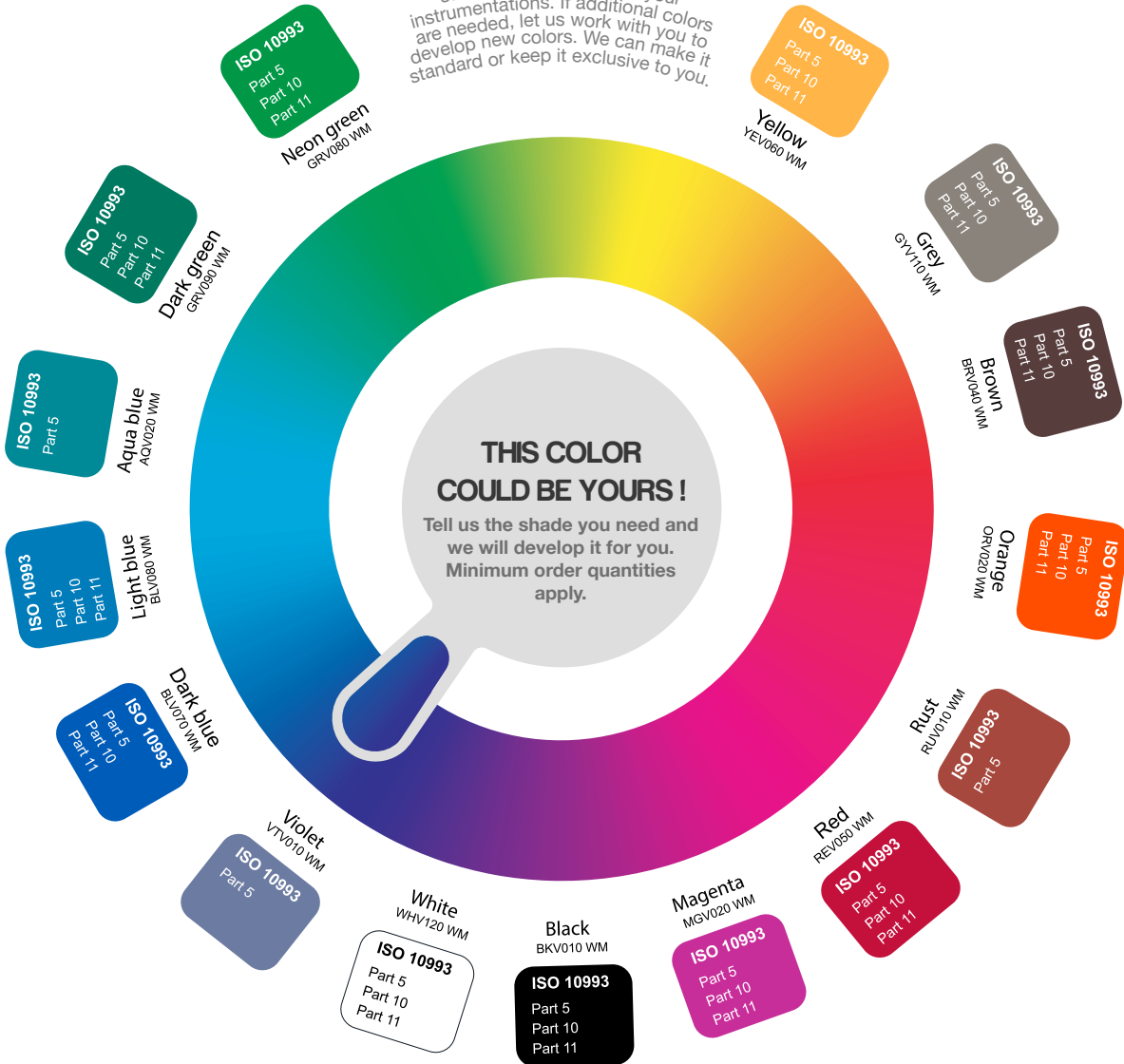

STANDARD DIAMETER RANGE

Custom diameters are available upon request. Minimum order quantities would apply.

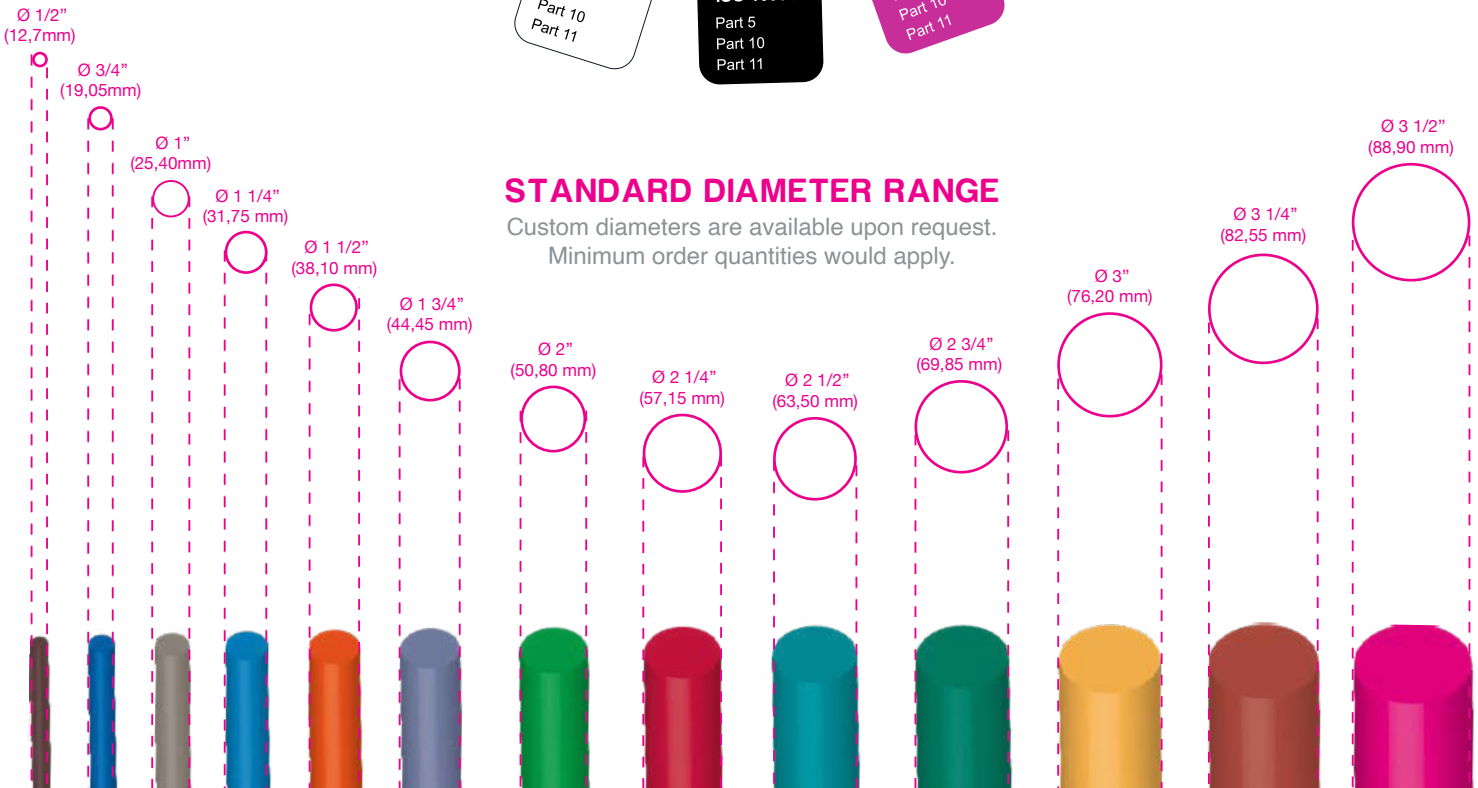

STANDARD LENGTH : 8ft / 2438mm

STANDARD LENGTH : 4ft / 1219mm

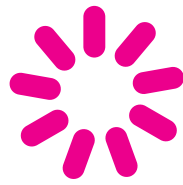
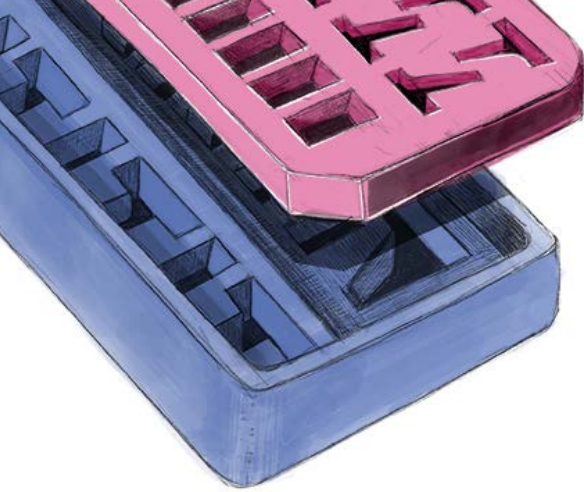

Westlake ASSISTANCE

Westlake can make performance validation easy.

When you consider using **PROPYLUX® HS** for a new project or a legacy instrument, our team is at your service to help execute your plan! We understand the biocompatibility profile is important and product validation is crucial. Let us help you through this process : we can help define a protocol, machine prototypes, run multiple autoclaving cycles and perform dimensional evaluation.

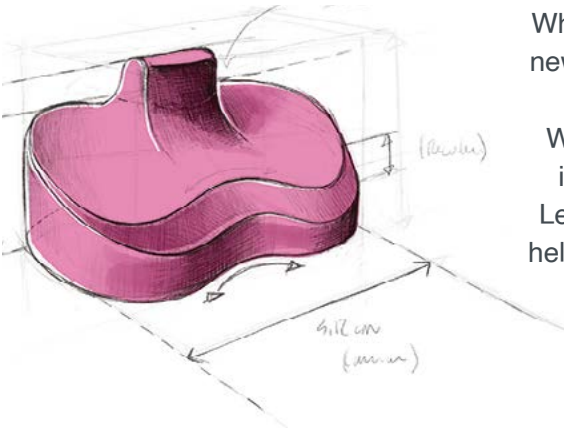
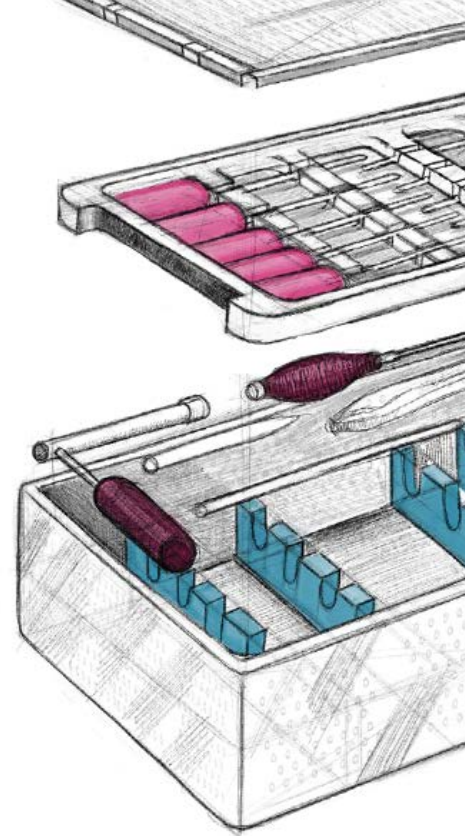

Case Study & Testimonial

PROPYLUX® HS was successfully used for the manufacturing of In'tech Medical's bumper on a femoral implant holder. While alternative polymers were evaluated, **PROPYLUX® HS** showed the best performance. Its high ductility makes it an excellent option for impactor devices.

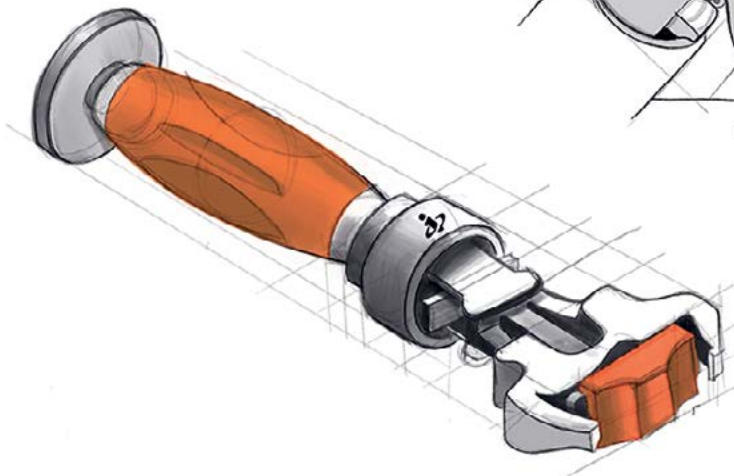
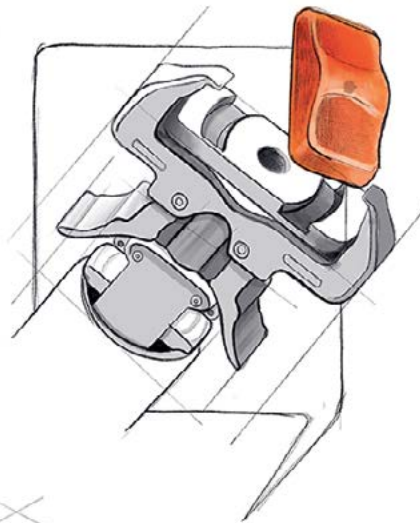

IN'TECH MEDICAL
MANUFACTURING SOLUTIONS

"We recently developed a unique femoral impactor which can be adapted to every OEM's condyle implant geometry by switching out the bumper. This allows us to minimize customizations & provide the market with a turn-key OEM instrument. The bumper is instrumental as it ensures a snug fit with femoral condyle implant while transferring energy required for final positioning of implant in patient's femur. Looking at our needs, Westlake Plastics assisted us in picking the best material for our application, which turned out to be **PROPYLUX® HS**. Indeed, the bumper needed to be strong enough to absorb repeated shocks & we did not want material to lose its properties or become brittle over time. On top of that, the complete biocompatibility profile made validation an easy process!"

Patrick Khalife – Director of R&D
Phone: + 1 901 375 1109
1407 Union Avenue | #1204
Memphis , TN 38104



PP **PROPYLUX[®] HS**

The Clear Solution for Orthopedic Devices

We have designed **PROPYLUX[®] HS** to be the most cost effective solution on the market. It offers excellent dimensional stability, chemical resistance and biocompatibility compliance compared to other medical grade polymers available in the market today and its color range is second to none. Westlake Plastics carries an extensive inventory to serve the orthopedic device market.

<p>Dimensionally Stable</p>	<p>Chemically Resistant</p>	<p>Sterilizable in Autoclave</p>
<p>Easy to Machine</p>	<p>ISO 10993 & FDA COMPLIANT</p>	<p>Laser Markable</p>



490 West Lenni road
Lenni, PA 19052
U.S.A
Phone : 1.610.459.1000
Phone : 1.800.999.1700
Fax : 877.789.0601
Web : www.westlakeplastics.com
Email : info@westlakeplastics.com



WESTLAKE PLASTICS EUROPE
2 Rue de Maestricht
59200 TOURCOING
FRANCE
Phone : (33) 03.20.68.30.35
Web : www.wp-europe.com
Email : info@wp-europe.com



FDA registered: #3011274144
21 CFR 820 compliant

Distributed by



SPECIALIST ENGINEERING PLASTICS
Units 3&4 Ellesmere Business Park
Swingbridge Road - Grantham
Lincolnshire - NG31 7XT
UNITED KINGDOM
Phone : 01476 574 476
Fax : 01476 592 262
email : sales@Seplastic.com
www.seplastic.com